

KOMATSU

WA470-8



Wheel loader

Engine power
204 kW / 273 HP @ 2000 rpm

Operating weight
24170 - 25670 kg

Bucket capacity
4.1 - 6.0 m³

WA470-8



Engine power

204 kW / 273 HP @ 2000 rpm

Operating weight

24170 - 25670 kg

Bucket capacity

4.1 - 6.0 m³

Increased fuel efficiency and environmental performance

Powerful and environmentally friendly

- EU Stage V engine
- Komatsu SmartLoader Logic
- E-Light engine mode
- Large-capacity torque converter with standard lock-up
- Adjustable idle shutdown

First-class comfort

- New, air-suspended operator seat with integrated EPC lever console
- Large multifunctional monitor
- Low-noise design
- Rear-view camera system

Maximised efficiency

- High efficiency buckets
- Superior dumping height and reach
- Wide tread and long wheelbase

State-of-the-art controls

- Automatic digging system
- Electronic Pilot Control (EPC) standard
- Intelligent gas pedal

Easy maintenance

- Wide core radiator with auto reverse fan
- Factory fitted automatic lubrication system
- Improved gull-wing type engine doors

Komtrax

- Komatsu Wireless Monitoring System
- 4G mobile communications
- Integrated communication antenna
- Increased operational data and fuel savings



A maintenance program
for Komatsu customers



Komatsu SmartLoader Logic

The WA470-8 provides Komatsu SmartLoader Logic, a fully automatic engine control system. Without interfering with normal operations, this technology acquires data from various sensors in the vehicle and delivers optimal engine torque for each work phase. It limits torque during less demanding operations and reduces fuel usage without decreasing production.

Large-capacity torque converter with standard lock-up

With its large-capacity torque converter, the completely redesigned Komatsu drive train offers optimum efficiency and an unparalleled rimpull-to-weight ratio. By delivering high rimpull at low speeds, it makes child's play of heavy jobs like penetration of dense material such as aggregate. This means higher productivity in V-Shape loading, even in confined spaces.

New E-Light mode

The new E-Light mode is switched on by default for low fuel consumption priority. The engine matches power to the current working phase to achieve higher fuel efficiency. For more fuel economy, the electronically controlled hydraulics pumps for the work and steering system prevent wasted hydraulic flow and deliver the exact amount of oil required for all movements of the machine.

Powerful and environmentally friendly

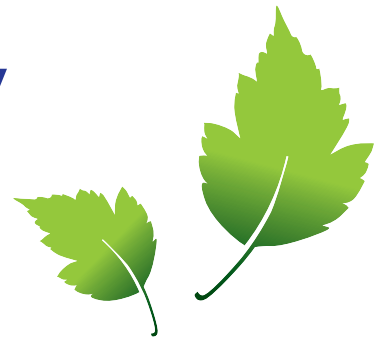

Komatsu EU Stage V

The Komatsu EU Stage V engine is productive, dependable and efficient. With ultra-low emissions, it provides a lower environmental impact and a superior performance to help reduce operating costs and lets the operator work in complete peace of mind.

Heavy-duty aftertreatment

The aftertreatment system combines a Komatsu Diesel Particulate Filter (KDPF) and Selective Catalytic Reduction (SCR). The SCR injects the correct amount of AdBlue® into the system at the proper rate to break down NOx into water (H₂O) and non-toxic nitrogen gas (N₂). NOx emissions are reduced by 80% vs. EU Stage IIIB engines.

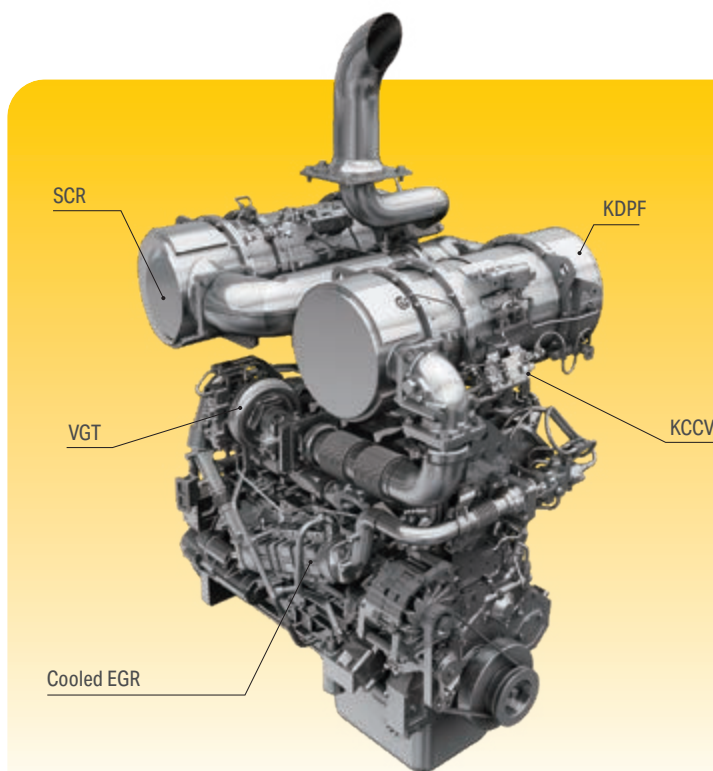
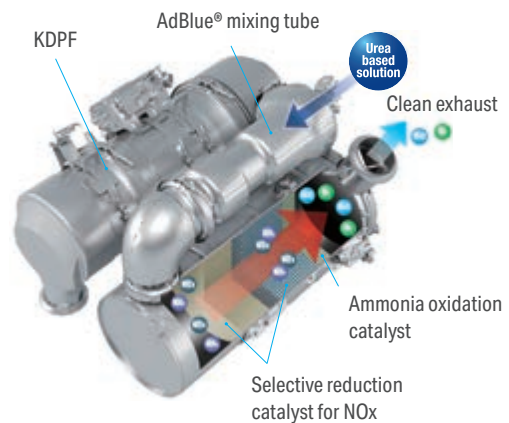

High-Pressure Common Rail (HPCR)

To achieve complete fuel burn and lower exhaust emissions, the heavy-duty High-Pressure Common Rail fuel injection system is computer controlled to deliver a precise quantity of pressurised fuel into the redesigned engine combustion chamber by multiple injections.

Exhaust Gas Recirculation (EGR)

Cooled EGR is a technology well-proven in current Komatsu engines. The increased capacity of the EGR cooler now ensures very low NOx emissions and a better engine performance.

Komatsu Closed Crankcase Ventilation (KCCV)

Crankcase emissions (blow-by gas) are passed through a CCV filter. The oil mist trapped in the filter is returned back to the crankcase while the filtered gas is returned to the air intake.

Variable Geometry Turbo (VGT)

The VGT provides optimal airflow to the engine combustion chamber under all speed and load conditions. Exhaust gas is cleaner, fuel economy is improved while machine power and performance are maintained.

Maximised efficiency

Faster Load & Carry

The sequential torque converter lock-up system delivers unbeatable productivity and fuel efficiency in Load & Carry and short distance transport applications. The operator can engage the system from 2nd to 4th gear. It noticeably increases travel speed, particularly when going uphill, thanks to the larger tractive force. It also significantly reduces fuel consumption by eliminating converter losses.

Superior dumping height and reach

The long lifting frame allows an enormous dumping height of 2865 mm and a reach of 1485 mm that is just as impressive (with a 4.2 m³ bucket, measured to the tooth tip). With this working range, loading high feeders or trucks becomes easy and fast.

New high efficiency buckets

Soil slips easily from the redesigned bucket, and digging work is more efficient. Operations are easier and productivity improved, especially in combination with the new auto digging system.

Precision control

Komatsu's CLSS hydraulics enables extremely precise control of the work equipment, and ensures that the bucket, boom and hydraulically driven attachments can all move smoothly at the same time. The WA470-8 also features variable-displacement pumps on both the hydraulic and steering systems. These pumps deliver the exact amount of oil required, dramatically improving fuel efficiency.



Factory installed RDS weighing system (option)

The RDS Loadmaster alpha 100 is an advanced and trade-approved on-board weighing system specifically designed to operate in the fastest loading environments and toughest conditions. The Loadmaster compensates for uneven, sloped ground and restricted loading areas to reduce your cycle times and maximise tonnes-per-hour performance. The RDS Loadmaster alpha 100 factory installation enhances the assembly's accuracy and the quality of the system.





First-class comfort

Increased comfort

In the wide Komatsu SpaceCab™, a standard air-suspended high-back seat, heated for improved comfort and with fully adjustable armrests, is the centre of a comfortable and low-fatigue working environment. High visibility and ergonomic controls further assist to maximise the operator's productivity.

Perfect operator convenience

In addition to the standard radio, the WA470-8 has an auxiliary input for connecting external devices and play music through the cab speakers. Two 12-volt power ports are also incorporated in the cab. Proportional controls are fitted as standard for safe and precise operation of attachments. The cab features large trays and storage boxes for tools and manuals and a hot and cool box.

New automatic digging system

The new automatic digging system actuates the bucket tilt and lifting operations by detecting the sensing pressure applied to the work equipment. The system adapts to different types of material with no human intervention required. Operator fatigue is greatly reduced and ideal load capacity ensured.



State-of-the-art controls

New, fully air suspended operator station

The wide spacious cab features a new, fully air suspended operator seat that includes the side consoles mounted together with a high back, fully adjustable, standard heated seat for improved comfort. A seat ventilation is optionally available to maximise comfort.

“By wire” operating

The Electronic Pilot Control (EPC) lever console is integrated with the seat and can be easily adjusted to suit any operator. The short levers are fingertip controlled for precise and fatigue-free operating, with a no-vibration modulating function for slowing and stopping a lowering bucket. The upper and lower boom cut-out position can be pre-set with a switch.

Intelligent gas pedal

To reduce fuel usage, Komatsu’s innovative thrust-sensing gas pedal automatically helps you match the timing of gear shifts to the load. In heavy-duty work, requiring high rimpull and maximum acceleration, we tend to press heavily on the gas pedal. The WA470-8 anticipates this and shifts up gears as late as possible. In light-duty work, where fuel consumption is a major factor, the operator will intuitively press the gas pedal lightly. Again, the machine anticipates this – and shifts up gears as early as possible to achieve highest fuel efficiency.

Rear view camera

A standard fitment camera gives an exceptionally clear view of the rear work zone on the wide-screen colour monitor panel. The low profile camera is adjustable and integrated into the engine hood’s shape.

EPC-multi-function lever (option)

The EPC-multi-function lever with an integrated forward/reverse switch allows the simplest and most comfortable operation of the equipment. With one hand the driver can simultaneously control the attachment and switch between forward and reverse. The multi-function lever is the perfect choice for earth moving jobs.

Komatsu Short Lever Steering (K-SLS) (option)

The new finger-type joystick steering allows more accurate steering by the operator who can now sit relaxed in the new air-suspended and fully adjustable seat to control the machine with no big effort needed for frequent steering. Less fatigue and work in a perfectly adapted operating position will improve concentration and the quality and efficiency of the work.



Komatsu Short Lever Steering (K-SLS) (option)



Hot and cool box



EPC-multi-function lever (option)



Lower operating costs

Komatsu ICT contributes to the reduction of operating costs by assisting to comfortably and efficiently manage operations. It raises the level of customer satisfaction and the competitive edge of our products.

Large TFT colour monitor

A large user-friendly colour monitor enables safe, accurate and smooth work. Multilingual and with all essential information available at a glance, it features simple and easy-to-operate switches and multifunction keys that provide fingertip access to a wide range of functions and operating information.

Eco guidance

The monitor panel displays instant guidance messages to help promote energy saving, and the Eco-gauge indicates the actual fuel consumption: keep the Eco-gauge in the green zone for better fuel efficiency. To further improve savings, logs can be consulted for operations, Eco guidance and fuel consumption. The information is available in Komtrax and can be used for operator trainings and jobsite optimisation.



Information at a glance: basic dashboard LCD monitor



A multifunction monitor displays and controls a wealth of operational and maintenance information



Eco guidance supports energy saving in real time (e.g. avoid long time engine idling)

Information & communication technology



Knowledge

You get quick answers to basic and critical questions about your machines – what they're doing, when they did it, where they're located, how they can be used more efficiently and when they need to be serviced. Performance data is relayed by wireless communication technology (satellite, GPRS or 4G depending on model) from the machine to a computer and to the local Komatsu distributor – who's readily available for expert analysis and feedback.

Convenience

Komtrax enables convenient fleet management on the web, wherever you are. Data is analysed and packaged specifically for effortless and intuitive viewing in maps, lists, graphs and charts. You can foresee eventual maintenance issues and required spare parts, and troubleshoot a problem before Komatsu technicians arrive on site.



The way to higher productivity

Komtrax uses the latest wireless monitoring technology. Compatible on PC, smartphone or tablet, it delivers insightful and cost saving information about your fleet and equipment, and offers a wealth of information to facilitate peak machine performance. By creating a tightly integrated web of support it allows proactive and preventive maintenance and helps to efficiently run a business.

Power

The detailed information that Komtrax puts at your fingertips 24 hours a day, 7 days a week gives the power to make better daily and long-term strategic decisions – at no extra cost. Problems can be anticipated, maintenance schedules customised, downtime minimised and machines kept where they belong: working on the jobsite.



Easy maintenance



Easy access to service points

For easy and safe opening the gull-wing doors are supported by gas springs. The large doors give a convenient access from ground level to all daily service points. With long service intervals and filters collected in a centralised arrangement, machine downtime is reduced to a minimum.

Komatsu Care

Komatsu Care is a maintenance program that comes as standard with your new Komatsu machine. It covers factory-scheduled maintenance, performed with Komatsu Genuine parts by Komatsu-trained technicians. Depending on your machine's engine, it also offers extended coverage of the Komatsu Diesel Particulate Filter (KDPF) and of the Selective Catalytic Reduction (SCR). Please contact your local Komatsu distributor for terms and conditions.



Wide core radiator with auto reverse fan

A wide core radiator prevents clogging even when working in a dusty environment. To minimize manual cleaning, a reversible fan blows dust out, automatically or on demand. The "automatic reverse" function allows to set the cleaning length and the time between cleaning to adjust perfectly to the working conditions.

Equipment Management Monitoring System (EMMS)

The large high resolution monitor panel displays various machine information and allows for multiple settings. The "Operation Records" menu shows records of the average fuel consumption, idling hours, and other features. Abnormality codes are clearly displayed and stored to alert you and simplify troubleshooting. The monitor also provides for advanced monitoring of the system parameters through the Service Mode to aid in troubleshooting and reduce downtime.



AdBlue® tank

The AdBlue® tank is located on the right hand side of the machine behind a ladder for easy access.

Diesel particulate filter regeneration

No interruption or extension of daily work is required to regenerate the diesel particle filter system. Due to its superior Komatsu technology, KDPF regeneration takes place automatically, at any time.





Basic maintenance screen

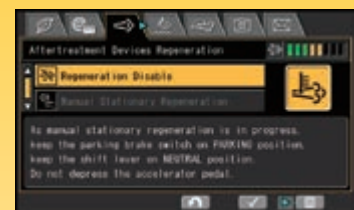

Aftertreatment device regeneration screen for the KDPF



AdBlue® level gauge and refill guidance



Tailored solutions



Working gear division

Komatsu wheel loaders combined with a wide range of genuine Komatsu attachments provide the perfect solution for any industry sector. For special applications our "Working Gear" division offers purpose-built machines and attachments. The tailor made solutions allow high performance and outstanding reliability even under toughest conditions.

Waste & Recycling

Renowned for high quality standards and reliability, Komatsu meets the huge demand placed on machines by the waste management industry with a wide range of options and modifications available ex factory for our base machines. This provides the flexibility to adapt the Komatsu wheel loader range to the specific requirements of different waste handling applications and jobsite conditions. Whether you choose the full waste specification or individual components, you're guaranteed increased machine performance, availability and efficiency.

Salt & Chemical

A corrosive environment is one of the toughest challenges for any machine. Upgraded with a special coating on the metal parts and with various optional modifications to fit the application at hand, Komatsu "Salt & Chemical" configured wheel loaders hold up even under the most aggressive conditions. Reduced downtime, less maintenance and repair costs and a long lifetime: Komatsu machines perform as well and last as long as in a non-corrosive environment.

Quality you can rely on

Designed and built by Komatsu

The engine, hydraulics, power train, front and rear axles are original Komatsu components. All these components are subject to the highest quality standards right down to the smallest screw. All components are fully co-ordinated with one another, thus offering the maximum efficiency and reliability.

Heavy-duty axles

The heavy-duty axles allow exceptional service life even under the toughest working conditions. The optional limited slip differentials are most suitable for soft and slippery ground like sand or wet soil.

Robust torsion-resistant main frame

The frame design with hinge points far apart guarantees the high stability for the overall construction and reduces bearing stress in the torsional ranges.

Axle oil cooling system

Overheated axle oil can cause a decline in productivity due to required machine cool downs. To maintain high efficiency in Load & Carry applications, the Komatsu WA470-8 is equipped as standard with an axle oil cooling system that keeps oil at a constant temperature even over long hauling distances.

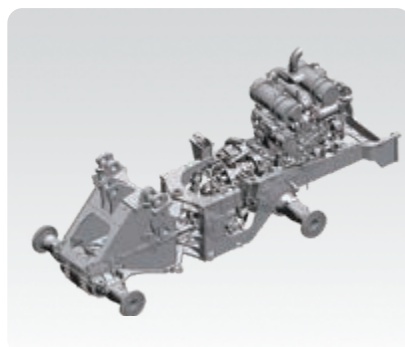

Robust torsion-resistant main frame

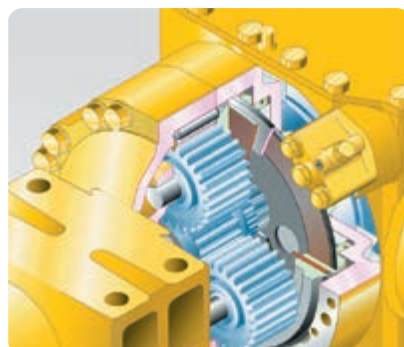

Wet multi-disc service brake

Buckets and attachments

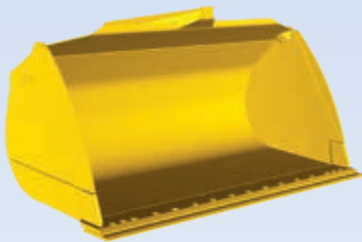

High efficiency buckets with raised bottom

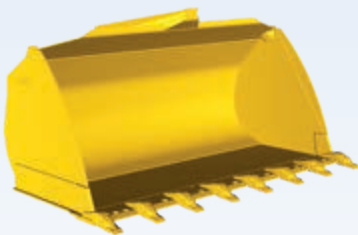

High efficiency buckets with flat bottom

New high efficiency bucket range

The new Komatsu buckets enable easier bucket fill and significantly higher fill factors, contributing to more efficiency and less fuel consumption. They feature a longer bottom allowing for more content, a wider opening for an easier fill and a new rear shape that enables material to flow easily into the bucket. Their rounded sides give them a higher fill factor, and an integrated spill guard protects the bucket linkage. Flush screws (with BOC) reduce resistance when filling and keep material from clogging when dumping.

High dump buckets

For maximum dumping heights with light materials like coal or woodchips. The dump cylinders are located either inside or outside the bucket.

Mulch grab buckets

Perfectly suited for picking up bulky and compressible materials like gardening or plastic waste, etc. Without the side plates, this bucket can be used also as a grapple.

Hydraulic quick coupler

The WA470-8 can change attachments in a matter of seconds with the HD hydraulic quick-coupler, available as optional equipment.



Specifications

Engine

Model	Komatsu SAA6D125E-7
Type	Common rail direct injection, water-cooled, emissionised, turbocharged, after-cooled diesel
Engine power	
at rated engine speed	2000 rpm
ISO 14396	204 kW / 273 HP
ISO 9249 (net engine power)	203 kW / 272 HP
Max. torque / engine speed	1330 Nm / 1450 rpm
No. of cylinders	6
Bore × stroke	125 × 150 mm
Displacement	11.04 l
Fan drive type	Hydraulic
Alternator	90 A / 24 V
Starter motor	7.5 kW / 24 V
Filter	Main-flow filter with water separator
Air-filter type	Dry-air filter with automatic dust emission and preliminary purification including a dust display
Fuel	Diesel fuel, conforming to EN590 Class 2/Grade D. Paraffinic fuel capability (HVO, GTL, BTL), conforming to EN 15940:2016

Transmission

Type	Automatic powershift transmission
Torque converter	One-stage, two-phase, 3-element, with lock-up clutch

Speeds in km/h (with 26.5 R25 tyres)

Gear	1.	2.	3.	4.
Forward	7.6	13.1	22.9	36.2
with torque converter lock-up	-	13.2	23.6	38.3
Reverse	7.9	13.5	23.6	37.3
with torque converter lock-up	-	13.7	24.3	39.0

Chassis and tyres

System	4-wheel drive
Front axle	Komatsu HD axle, semi-floating (LSD-differential optional)
Rear axle	Komatsu HD axle, semi-floating, 26° swing angle (LSD-differential optional)
Differential	Spiral bevel gear pair
Final drive	Planetary gear in an oil bath
Tyres	26.5 R25

WA470-8E0

Brakes

Operating brakes	Hydraulically actuated, wet multi-disc brakes on all wheels
Parking brake	Wet multi-disc
Emergency brake	Uses the parking brake

Hydraulic system

Type	Komatsu CLSS (Closed Centre Load Sensing System)
Hydraulic pump	Variable piston pump
Working pressure	350 kg/cm ²
Maximum pump flow	260 l/min
No. of hydraulic / bucket cylinders	2/1
Type	Double-action
Bore diameter × stroke	
Boom cylinder	140 × 764 mm
Bucket cylinder	160 × 575 mm
Hydraulic cycle with rated load bucket filling	
Raise time	5.8 s
Lowering time (empty)	3.1 s
Dumping time	1.6 s

Steering system

System	Articulated frame steering
Type	Completely hydraulic power steering
Steering angle to either side	40°
Steering pump	Variable piston pump
Working pressure	250 kg/cm ²
Pumping capacity	195 l/min
No. of steering cylinders	2
Type	Double-action
Bore diameter × stroke	90 × 441 mm
Smallest turn (outer edge of the tyre 26.5 R25)	6270 mm

Cabin

Two-door SpaceCab™ in conformity with ISO 3471 with ROPS (roll over protective structure) in conformity with SAE J1040c and FOPS (falling object protective structure) in conformity with ISO 3449. The air-conditioned pressurised cabin is mounted upon hydrobearings and is noise dampened.

Service refill capacities

Fuel tank	380 l
Engine oil	38 l
Hydraulic system	173 l
Cooling system	78 l
Front axle	57 l
Rear axle	56 l
Torque converter and transmission	65 l
AdBlue® tank	36 l

Environment

Engine emissions	Fully complies with EU Stage V exhaust emission regulations
Noise levels	
LwA external	107 dB(A) (2000/14/EC Stage II)
LpA operator ear	70 dB(A) (ISO 6396 dynamic test)
Vibration levels (EN 12096:1997)	
Hand/arm	≤ 2.5 m/s ² (uncertainty K = 2.31 m/s ²)
Body	≤ 0.5 m/s ² (uncertainty K = 0.58 m/s ²)
Contains fluorinated greenhouse gas HFC-134a (GWP 1430). Quantity of gas 1.1 kg, CO ₂ equivalent 1.57 t.	

Bucket selection guide

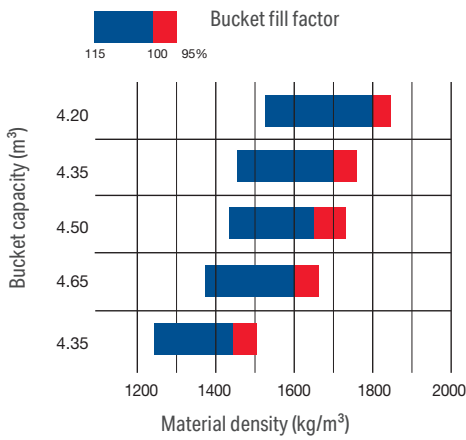

- Bucket with flat bottom with teeth (C52)
- Bucket with flat bottom with BOC (C57)
- Bucket with raised bottom with teeth (C76)
- Bucket with raised bottom with BOC (C77)
- Bucket with flat bottom with BOC (C53) (High-lift equipment)

Typical material density – loose (in kg/m³)

Basalt	1960	Gravel, unscreened	1930	Sandstone	1510
Bauxite, kaolin	1420	Gravel, dry	1510	Slate	1250
Earth, dry, ex store	1510	Gravel, dry, 6 - 50 mm	1690	Slag, broken	1750
Earth, wet, excavated	1600	Gravel, wet, 6 - 50 mm	2020	Stone, crushed	1600
Gypsum, broken	1810	Sand, dry, loose	1420	Clay, natural	1660
Gypsum, crushed	1600	Sand, damp	1690	Clay, dry	1480
Granite, broken	1660	Sand, wet	1840	Clay, wet	1660
Limestone, broken	1540	Sand and clay, loose	1600	Clay and gravel, dry	1420
Limestone, crushed	1540	Sand and gravel, dry	1720	Clay and gravel, wet	1540

Dimensions and performance figures

Measurements and working specifications

Bucket type		Bucket with flat bottom		Bucket with flat bottom (Heavy Duty)	
		w. teeth	w. BOC	w. teeth	w. BOC
Bucket capacity (heaped, ISO 7546)	m³	4.2	4.35	4.2	4.35
Sales code		C52	C53	C56	C57
Material density	t/m ³	1.8	1.7	1.8	1.7
Bucket weight	kg	2245	2300	2245	2300
Static tipping load, straight	kg	18915	18715	18915	18715
Static tipping load, 40° articulated	kg	16225	16050	16225	16050
Break-out force hydraulic	kN	190	179	190	179
Lifting capability hydr. at ground level	kN	210	205	210	20
Operating weight	kg	24225	24275	24225	24275
Turning radius at corner of tyres	mm	6270	6270	6270	6270
Turning radius at bucket edge	mm	7030	6975	7030	6975
a Reach at 45°	mm	1485	1345	1485	1345
b Dumping height at 45°	mm	2865	2985	2865	2985
c Hinge pin height	mm	4335	4335	4335	4335
d Height top edge of bucket	mm	5895	5895	5895	5895
e Digging depth	mm	125	155	125	155
f Max. loading height at 45°	mm	4020	4020	4020	4020
A Overall length, bucket grounded	mm	9350	9180	9350	9180
B Wheel base	mm	3450	3450	3450	3450
C Bucket width	mm	2990	2990	2990	2990
D Width over tyres	mm	2915	2915	2915	2915
E Track width	mm	2240	2240	2240	2240
F Ground clearance	mm	505	505	505	505
H Overall height	mm	3475	3475	3475	3475

All measurements with tyres 26.5 R25 (XHA) and standard counterweight.
 Details of dumping heights and reach to cutting edge or bolt-on cutting edge (BOC) or teeth.

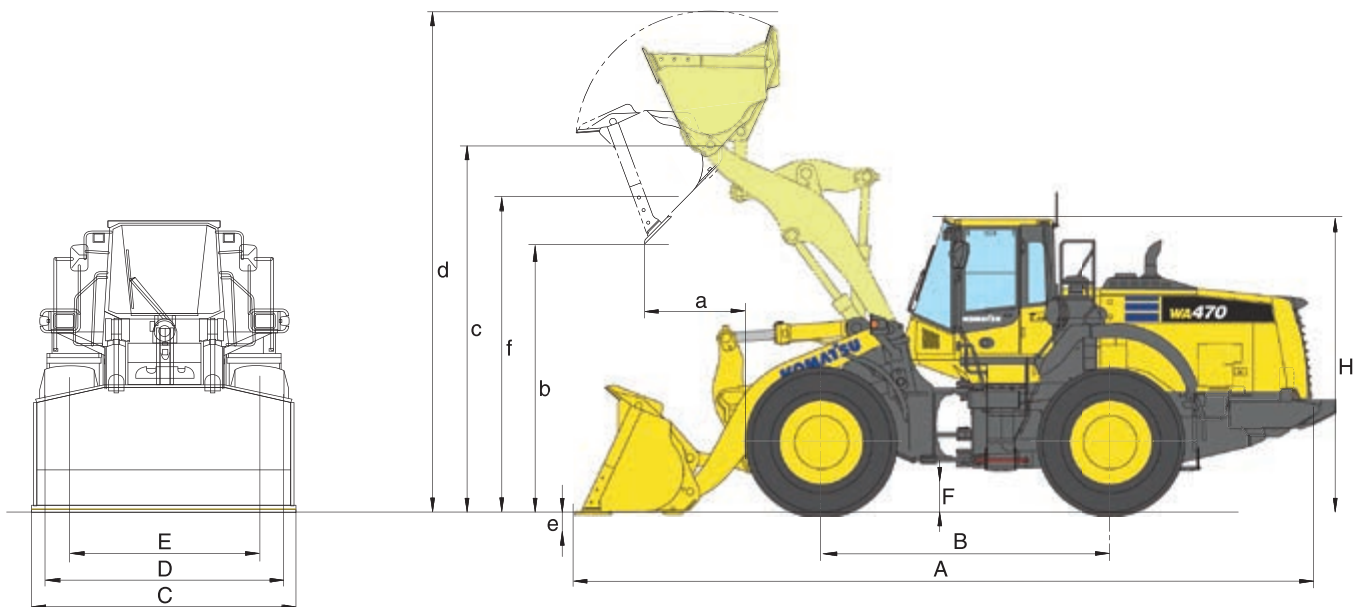

				High-lift equipment*			
Bucket with raised bottom				Bucket with flat bottom		Bucket with raised bottom	
w. teeth	w. BOC	w. teeth	w. BOC	w. teeth	w. BOC	w. teeth	w. BOC
4.5	4.65	4.7	4.9	4.2	4.35	4.5	4.65
C76	C77	S07S20S40	S07S20S30	C52	C53	S04S20S30	S04S20S40
1.65	1.6	1.6	1.55	1.55	1.45	1.45	1.4
2190	2240	2285	2345	2245	2300	2190	2240
19035	18845	18940	18715	16340	16180	16430	16265
16345	16165	16245	16040	13860	13715	13945	13795
183	173	180	201	185	175	178	169
210	206	202	170	164	162	165	162
24165	24220	24260	24325	25615	25665	25555	26610
6270	6270	6270	6270	6270	6270	6270	6270
7050	6990	7120	7065	7310	7245	7330	7265
1520	1380	1520	1380	1645	1505	1685	1540
2830	2955	2830	2955	3375	3505	3345	3465
4335	4335	4335	4335	4850	4850	4850	4850
5945	5945	5945	5945	6410	6410	6455	6455
125	155	125	155	265	295	265	295
4020	4020	4020	4020	4525	4525	4525	4525
9400	9230	9400	9230	9945	9775	9995	9825
3450	3450	3200	3200	3450	3450	3450	3450
2990	2990	3160	3170	3000	3000	3000	3000
2915	2915	2915	2915	2915	2915	2915	2915
2240	2240	2240	2240	2240	2240	2240	2240
505	505	505	505	505	505	505	505
3475	3475	3475	3475	3475	3475	3475	3475

* with additional counterweight A23

Change in data caused by:

		Add. counterweight A15	Heavy counterweight A23	StVZO counterweight A06	Tyres GP-4D	Tyres XMINE L5
Operating weight	kg	+400	+980	-570	+370	+1125
Static tipping load, straight	kg	+980	+2340	-1380	+325	+840
Static tipping load, 40° articulated	kg	+820	+1950	-1150	+260	+740
Overall length	mm	+175	+80	-114	-	-
Reach at 45°	mm	-	-	-	-15	-30
Dump height at 45°	mm	-	-	-	+15	+30
Width over tyres	mm	-	-	-	+30	+45
Overall height	mm	-	-	-	+15	+30

Standard and optional equipment

Engine

Komatsu SAA6D125E-7 turbocharged common rail direct injection diesel engine	●
EU Stage V compliant	●
Engine mode selection system: Power, Economy, E-Light	●
Komatsu SmartLoader Logic	●
Adjustable idle shutdown	●
Auto-deceleration function	●
Fuel filter with water separator	●
Batteries 2 × 180 Ah / 2 × 12 V	●

Chassis and tyres

Heavy-duty axles	●
Front fenders	●
Full rear fenders	●
Limited-slip differential (LSD) front and rear	○
Tyres 26.5 R25 L2, L3, L5	○

Hydraulic system

2-spool main control valve	●
EPC fingertip control, two levers, including:	
- Bucket stop modulation	●
- Boom stop pre-setting	●
- Automatic dig function	●
Automatic return-to-dig	●
3-spool main control valve	○
EPC fingertip control, three levers	○
EPC 1-lever (Multi-function lever) with sliding proportional control for attachments	○
Biodegradable oil for hydraulic system	○

Transmission and brakes

Electronically controlled ECMV automatic transmission with mode selector and variable transmission cut-off	●
Transmission shift mode selection system	●
Large-capacity torque converter	●
Torque converter lock-up	●
Auto-kickdown	●
Axle oil cooling system	●

Cabin

Spacious double door driver's cab to DIN/ISO	●
ROPS/FOPS frame according to SAE	●
Heated, high back air suspension seat, console mounted height adjustable arm rests	●
Retractable seat belt	●
Automatic climate control system	●
Multi-function video compatible colour monitor with Equipment Management and Monitoring System (EMMS) and efficiency guidance	●
DAB+ Radio with Bluetooth®, USB, AUX and hands-free kit	●
Hot and cool box	●
Heated rear window	●
Rear window wiper	●
Adjustable steering column	●
2 × 12 V power supply	●
Heated, high back air suspension seats with pneumatically adjustable lumbar support, console mounted height adjustable arm rests	○
3-point seat belt	○
Sun roller blind	○
Komatsu short lever steering (K-SLS)	○

Lighting system

2 halogen main headlights	●
2 spotlights at front and rear	●
Reversing light	●
Additional lights front and rear	○
LED working lights	○
Xenon working lights	○

Service and maintenance

Hydrostat-driven radiator fan with automatic reversing function	●
Wide core radiator	●
Komtrax – Komatsu Wireless Monitoring System (4G)	●
Komatsu Care – a maintenance program for Komatsu customers	●
Tool-set	●
Automatic central lubrication	●
Filling tool for central lubrication system	○
Turbo II air pre-cleaner, cyclone type	○

Safety equipment

Emergency steering system	●
Vandalism protection	●
Back-up alarm	●
Battery main switch	●
Handrails on left/right	●
Rear-view camera system	●
Front screen protective grid	○
Fire extinguisher	○
Beacon light	○
Roof rail	○
Rear view mirror, heated and remote control	○
Optical back-up alarm (strobe light)	○

Attachments

High-lift equipment	○
Hydraulic quick-coupler	○
High efficiency buckets with flat or raised bottom	○
High-dump buckets	○
Fork carrier and tines	○
Waste handling buckets	○
Light material buckets	○

Other equipment

Counterweight	●
Electronically controlled load stabilizer (ECSS II)	●
Special custom colour	○
Add. counterweight 400 kg (A15)	○
Heavy counterweight 980 kg (A23)	○
StVZO counterweight (A06)	○
Weighing system RDS Loadmaster alpha100	○
Anti-corrosion specification	○
Waste-handler specification	○
Cold area kit (engine and cab pre-heating)	○

Further equipment on request

- standard equipment
- optional equipment



A wide range of buckets and attachments is available. Your Komatsu distributor is ready to assist you with the selection of suitable options.

This specification sheet may contain attachments and optional equipment that are not available in your area. Please consult your local Komatsu distributor for those items you may require. Materials and specifications are subject to change without notice.

Your Komatsu partner:

KOMATSU

[komatsu.eu](https://www.komatsu.eu)

