

# KOMATSU

## HM460-6



Articulated dump truck

**Engine power**  
386 kW / 518 HP @ 1700 rpm

**Body capacity, heaped**  
25.7 m<sup>3</sup>

**Max. payload**  
42.0 metric tons



## *Reduced fuel consumption*

Compared to HM400-5



## *Increased fuel efficiency*

Compared to HM400-5

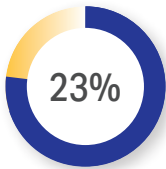

## *Increased engine torque*

Compared to HM400-5

## **First-class comfort**

- Very large operator cab with enhanced visibility
- Premium comfort operator seat
- Ergonomic layout of controls
- 8-inch machine monitor & 10-inch rear-view monitor
- Hill start assist
- Keyless start with operator identification system
- Cruise control and speed limiter
- Integrated DAB+ radio with Bluetooth®

## **Powerful and environmentally friendly**

- Powerful next generation Komatsu DBA127 engine with 386 kW
- Fully complies with EU Stage V and exhaust emission regulations
- New 9-gear transmission (9F/2R) and new smart gear control
- Strong and lightweight design, supporting higher payload capacity
- 100% differential locks with cross-axle differential lock system
- Komatsu Traction Control System (KTCS)
- Advanced payload meter (PLM)
- Adjustable idle shutdown & adjustable delayed engine shutdown



Engine power

**386 kW / 518 HP @ 1700 rpm**

Body capacity, heaped

**25.7 m<sup>3</sup>**

with tailgate

**26.8 m<sup>3</sup>**

Max. payload

**42.0 metric tons**

# Redesigned to conquer any terrain, Engineered for unrivalled efficiency

## Safe & easy operation

- Machine inclination monitoring
- Rollover prevention system
- Safe and stress-free dumping assistance functions
- LED lighting system
- Dumping lights
- Built-in brake inspection guidance
- Seat belt caution indicator with exterior green lamp

## Easy maintenance

- Significantly extended service intervals for oils, filters, and particle filter reduce maintenance costs
- Sampling ports for convenient oil sampling
- Power cab and engine hood tilt
- Improved air cleaner with pre-cleaner
- Reversible radiator and aftercooler fans
- Improved windscreen-wiper system
- Lightweight wheel chocks
- Komatsu Care program (regional differences apply)



## Digital assistance & guidance

- Komtrax – Komatsu wireless monitoring system
- Smart Construction Fleet (option)
- Smart Construction Smart Quarry Site (option)



## Significantly improved fuel efficiency

Newly designed powertrain components integrate the latest fuel consumption reduction technologies. The power generated by the engine, which offers both low fuel consumption and high output, is transmitted to the tyres by the highly efficient transmission and axles, enabling high driving performance. Additionally, the increased payload contributes to a significant improvement in fuel efficiency. Fuel efficiency is increased by up to 22%, fuel consumption up to 12% down depending on the actual work (compared to HM400-5).

## New generation transmission and new smart gear control

A new transmission with nine forward gears and two reverse gears, together with a new gear control, enables a significant improvement in fuel efficiency. The transmission runs at a lower engine speed, reducing fuel consumption. The gear control monitors both the payload and road-surface conditions, automatically selecting the most suitable gear for highly efficient operation.

### Automatic start shift selection

Depending on the vehicle's condition, the starting gear is automatically selected from first to third forward gear (F1 - F3), enabling a smooth and powerful start.

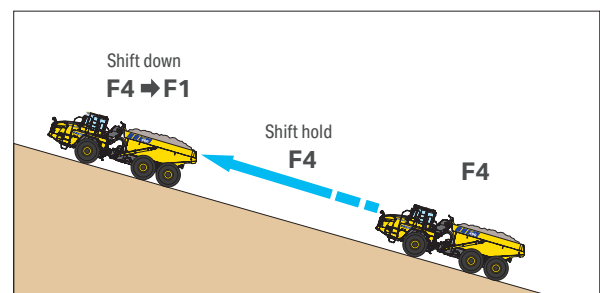

### Skip shift function

Automatically selects a gear position depending on the slope grade when driving uphill, without shifting down through each gear. It reduces the number of downshifts, makes driving smoother, improves operator comfort and reduces material spillage.

# Powerful and environmentally friendly

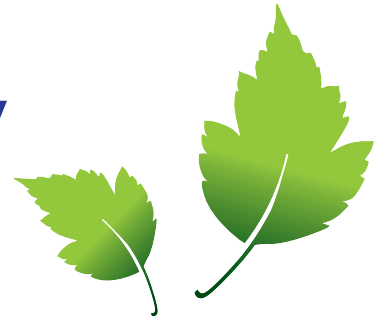

## Next-generation Komatsu DBA127 engine

The new engine delivers increased power and torque at lower revolutions, enhancing productivity while reducing operating costs. A streamlined design with fewer components makes the engine simpler, less complex, and easier to maintain. Engine power has increased by 9%, and maximum engine torque, now 2803 N·m, is up by a significant 23% (compared with the HM400-5). Incorporating the latest state-of-the-art technology, it burns fuel more efficiently and cleanly, achieving a significant reduction in emissions and CO<sub>2</sub> output. The new engine fully complies with both EU Stage V exhaust-emission regulations.

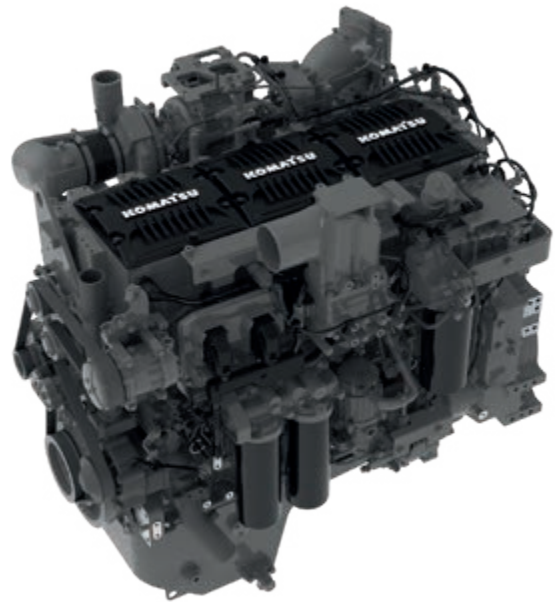

## Two-stage fixed-geometry turbocharger system



A fixed-geometry two-stage turbocharger system, consisting of two turbochargers arranged in series, supports the engine in delivering high power and excellent fuel

efficiency through effective turbocharging across the entire speed range.

## Engine-off management



Komatsu's auto idle shutdown and auto power-off functions automatically turn off the engine after it idles

for a preset period of 3 to 60 minutes, reducing unnecessary fuel consumption, exhaust emissions, and operating costs. The delayed engine shutdown uses the temperature monitoring system to allow even shorter idling times. In addition, an Eco-gauge and Eco-guidance tips on the cab monitor further support efficient operation.

## Selectable working modes

"Power mode" is for high production jobs and uphill hauling. It increases the engine's maximum output and raises the upshift and downshift engine speeds during operation. For lighter work on flat ground, the "Economy mode" will lower the engine's maximum output and the upshift and downshift speeds.

## HVO diesel fuel ready

Committed to reducing CO<sub>2</sub> emissions, Komatsu diesel engines are compatible with paraffinic fuels such as HVO, GTL and BTL, in line with EN 15940:2016. These cleaner alternatives reduce environmental impact without affecting performance.





## Outstanding off-road performance

The HM460-6 delivers outstanding off-road performance on soft ground thanks to the six-wheel drive system. In changing surface conditions, such as mud or uneven terrain, the combination of the Komatsu Traction Control System (KTCS) and the new cross-axle differential lock ensures stable traction, delivering outstanding control for safe, smooth and efficient operation.

### Komatsu Traction Control System (KTCS)

Enables both excellent terrain capability and manoeuvrability by optimally controlling traction when tyres slip.

### 100% differential lock

When the operator engages the differential lock pedal, the cross-axle and inter-axle differentials are locked simultaneously, providing maximum off-road performance on soft or uneven ground.

## Robust and lightweight design, enabling higher payload capacity

The front and rear frames are constructed using high-strength materials and a box-section design. By incorporating the latest technology, they achieve both light weight and durability, resulting in greater payload capacity. The body uses 450 HB-class wear-resistant steel plates in key areas,



contributing to weight reduction. The body capacity and maximum

payload have been significantly increased while maintaining durability. At 25.7 m<sup>3</sup>, the body capacity (heaped) is up by 7%, while the maximum payload has increased by 5%, depending on the actual equipment (compared with the HM400-5).

## Advanced payload meter (PLM)

The payload meter displays the number of loads, enabling easy management of production volume and operating conditions. Operation under optimal conditions is supported by the machine monitor, which shows the payload, and by exterior indication lamps that allows the loading machine operator to check the loading status. The cumulative payload and total cycle count can also be viewed on the machine monitor, with data available via the Komtrax server.



Payload display

Loaded weight

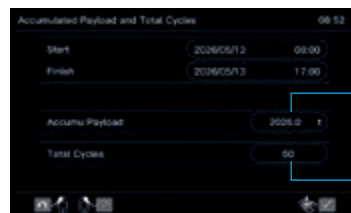

Cumulative load amount

Total cycle number





### **Automatic Retard Speed Control (ARSC)**

Downhill speed can be set independently for loaded and unloaded conditions with a single touch. The system automatically detects whether the truck is loaded or empty and adjusts the retarder force accordingly, enabling the driver to focus solely on steering during descent. Even with downhill speed control active, the set speed can be fine-tuned in 1 km/h increments (within a  $\pm 5$  km/h range) with a single touch, allowing smooth adaptation to changes in gradient.

### **Cruise control**

The system automatically adjusts throttle and retarder input to maintain the operator's selected speed. Whether traveling on level ground, uphill, or downhill, it ensures optimal driving performance and stability at all times. If the operator decelerates using the retarder lever, the system maintains the reduced speed once the lever is released. When bringing the vehicle to a complete stop using the lever, the waiting brake engages automatically to securely hold the vehicle in place. A single tap of the speed-up switch or pressing the accelerator pedal returns the vehicle to the preset speed. This feature delivers safe, comfortable operation suited to any worksite conditions.

## Safe & easy operation



### Speed limiter

The speed limiter allows the customer to set a maximum speed for each jobsite, limiting engine output to prevent the vehicle from exceeding the preset value. During downhill travel, the system maintains the maximum speed by applying the retarder. Separate maximum speeds can be configured for both loaded and unloaded conditions.\*

### Speed limiter, overload

The overload speed-limit function restricts vehicle speed when the payload exceeds the specified limit. Alternatively, the system can be configured to provide a visual and audible overload warning without applying a speed limit.\*

### Seat belt reminder system

This adjustable system combines a visual and audible alarm in the cab with an external lamp to increase job site safety. The green external lamp indicates to anyone outside whether or not the seatbelt is worn by the operator.



### Machine inclination monitoring

The machine inclination monitoring function displays the vehicle's roll angle (front and rear frames), slope angle, and steering angle on the monitor to help enhance operating safety.

### Hill start assist

Prevents rollback on slopes by applying the retarder brake until traction is established.



### Rollover prevention system

To help prevent rear-body rollover during turning and enhance safe operation, the system monitors vehicle speed and operating conditions, issuing an alarm and automatically limiting engine output when necessary. In addition, when the rear-frame roll angle becomes excessive, body-raising functions are restricted to further reduce the risk of rollover.



### Unique hydro-pneumatic suspension

On both the front and rear axle, Komatsu's unique trailing arm hydro-pneumatic suspension gives the HM460-6 a smooth ride with reduced pitching and excellent driving comfort. The front suspension pivot point is positioned in front of the wheel, further enhancing stability and shock absorption. Less shocks for the operator and for the machine components also mean less spilled material and increased durability, comfort and productivity.

\* For safety reasons, speed limiter settings can only be adjusted by Komatsu service staff



### Safe and convenient dumping operation

Dumping is controlled with one-finger operation through a three-stage detent system for raising and lowering. A lock switch beside the dump lever prevents accidental operation for added safety.

### Semi-auto dumping

During body raising, engine speed automatically increases for smooth, energy-efficient dumping without operating the accelerator pedal. If a body-angle limit is set, the body will stop at the specified angle.

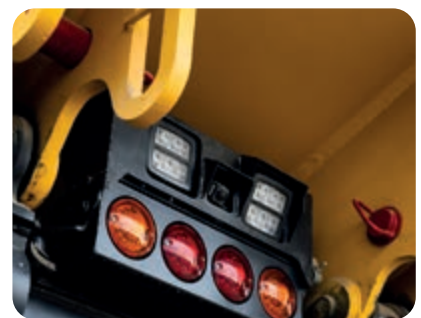

### Dump light

The rear work light and camera activate automatically during dumping, making it easier to confirm material discharge at night.

### Dump angle limitation

This function allows a maximum dump angle to be set to prevent contact when lift height is restricted. The angle can be adjusted to match worksite conditions.

## Safe & easy operation



### Engine shutdown secondary switches

In addition to the secondary engine shutdown switch in the cab, emergency engine shutdown switches are provided as standard for immediate shutdown in critical situations. These switches are located inside the cab and at both left and right ground level access points on the vehicle.

### Built-in ROPS / FOPS cab

The operator cab structure complies with ISO 3471 ROPS and ISO 3449 Level II FOPS standards.



### Under- and side-view mirrors

These mirrors provide clear visibility around the vehicle. The large side mirrors can also be folded by removing just two bolts per side, allowing for easy maintenance and transport.

### Waiting brake

The waiting brake automatically applies the retarder when the shift lever is in Neutral and the vehicle is stopped, reducing the need for retarder lever use during loading and dumping.

### Secondary steering

The secondary steering system automatically activates if steering hydraulic pressure drops due to a system failure. It can also be engaged manually using the secondary steering switch in the cab. Complies with ISO 5010 and SAE J1511.

### Three independent brake systems

The front, rear, and parking brakes each have their own independent circuits, ensuring braking capability even if one system experiences a malfunction.

### Secondary brake

Applies braking via the retarder lever, even if the brake pedal or foot brake circuit fails.

### Full LED lighting

LED lighting combines excellent visibility with long service life and energy-savings.





## New design cab

The HM460-6 features a newly designed, enlarged cab that offers exceptional comfort. Operators benefit from increased legroom and significantly improved visibility. A highly sound-insulated structure combined with viscous cab mounts minimizes noise and vibration, creating a spacious, ergonomic environment that reduces fatigue and supports sustained focus and productivity throughout the workday.

## Significantly enhanced visibility

The new cab delivers significantly improved all-around visibility. By positioning the operator's seat at the centre and precisely optimizing the location and shape of the A-pillars, front blind spots caused by the A-pillars and window frame have been reduced. In addition, removing the rear side pillars provides a wide, unobstructed field of view in all directions.



16% greater glass surface area and a 43% reduction in blind spots (vs. the HM400-5)



Rear visibility has been enhanced by removing the rear-left and rear-right pillars

## First-class comfort

### New air-suspension Deluxe seat

A newly engineered seat frame and cushion, designed with ergonomic principles, deliver enhanced comfort and operator support. The seat features an extended fore-aft adjustment range and a premium finish that combines high-quality fabric with genuine leather. For personalized comfort, it offers three-stage heating and adjustable side supports on both the cushion and backrest. A three-stage cooling system circulates cooled air to contact areas, helping reduce heat and moisture buildup in all conditions. For added safety, 4-point seatbelt options are available.



### Enhanced climate control

The HM460-6 features a sealed, pressurized cab and a high-capacity air-conditioning system with improved airflow and strategically positioned vents, providing a more comfortable and productive operating environment.



### Retractable steering column

The new flap-retracting steering column retracts easily with a single pedal and stays clear when entering or exiting the cab. The pedal-operated adjustment system allows quick control of the steering column angle, ensuring an ergonomic fit for any operator and enhancing driving comfort.



### Foldable trainer seat

The foldable trainer seat features a two-point seatbelt and enhanced cushioning for greater comfort. The seat surface folds away easily, providing convenient access when getting in and out of the cab.



### Front wiper

The wiper now covers 16% more surface area, providing clearer visibility and safer operation in rainy conditions.

### Sun visors

Retractable pull-down sun visors on the front, rear, and side windows keep the cab cooler, improving operator comfort.



### **Keyless start with operator identification system**

This machine is designed to adapt effortlessly to the individual preferences of every operator. Individual users can store their personal settings using Operator ID, with preferences automatically recalled at startup. The ID is accessed through code entry or a Bluetooth® key, which also allows for a secure, keyless start. Stored settings include basic preferences such as monitor configuration, drive train settings, and the selected engine mode at startup.

## First-class comfort



### Ergonomic controls for effortless operation

The positions of the shift lever and dump lever have been optimised for smooth driving and dumping control. The shift limit selection, shift hold lever, retarder lever, and speed setting lever are located on the steering column, allowing operators to stay focused on steering. The movement of the operator's hand has been reduced, helping reduce fatigue and support safe operation. Control switches are grouped on the right side, and frequently used switches are positioned within easy reach so operators can maintain steering focus and operate comfortably with reduced fatigue.



### Customisable dashboard for added equipment

The flat front dashboard offers a spacious operator area and a customisable layout for easy user modifications. It provides mounting space for additional devices, such as a CB radio, and is equipped with M8 mounting points for secure installation.



12 V and USB ports allow easy charging of personal devices. A dedicated phone compartment in the console, dashboard storage, a cup holder, a spacious hot/cool box, and other practical spaces help maintain an organised and clutter free workspace.



Additional storage is available under the trainer's seat, and when folded forward, the seat serves as a convenient storage tray.

## Information & communication technology



### High-definition machine monitor with intuitive navigation

The 8-inch machine monitor offers excellent visibility at a glance and is simple to operate, ensuring intuitive use. With a command selector toggle switch, operators can navigate the monitoring system easily. Shortcut buttons for core functions ensure even faster navigation. The interface also integrates climate control, DAB+ radio, and Bluetooth® media and phone connectivity. All machine information and data are provided in 27 local languages.



8-inch machine monitor

### Command selector toggle switch



The command selector has been newly introduced to operate the machine monitor. It allows intuitive navigation. By pressing the menu switch on the command selector, the display opens the user menu.

Functions are organised in clear tabs, allowing users to quickly find and display the desired function.



Instinctive and easily operable user menu

### Configurable settings

Vehicle settings can be customised to suit each application and operator preference, with a quick select function providing fast access to preferred display views.



10-inch touch screen rearview monitor

## Digital assistance & guidance



### KOMTRAX

#### The way to higher productivity

Komtrax turns telematics data into actionable insights for your fleet and equipment, empowering your business to make well-informed, data-driven decisions. By creating a tightly integrated web of support, Komtrax allows for proactive and preventive maintenance to minimise downtime and facilitate peak machine performance.

#### Productivity analytics for mixed fleets

Identify logistic bottlenecks, track cycle times and load volumes, and optimise site productivity in real time. Both solutions use geolocation data to give you actionable insights, and depending on your setup, you can choose the flexibility of Smart Construction Fleet or the advanced integration of Smart Quarry Site.



#### Smart Construction Fleet

Designed for speed and simplicity, Smart Construction Fleet provides a comprehensive overview of your operations by tracking nearly any equipment. Just plug the Smart Construction Fleet device into a 12 V outlet or use the mobile app, and the whole site is operational under 10 minutes.



#### Smart Quarry Site

Smart Quarry Site provides deeper, more detailed insights by integrating dedicated hardware directly with your equipment's CAN bus. An in-cabin monitor provides real-time payload data from dump trucks to loaders, helping operators work in sync for higher efficiency. Thanks to peer-to-peer communication, data keeps flowing even without network connection.

## Easy maintenance



### Easy maintenance access

The lightweight, powered tiltable engine hood provides enhanced maintenance access, enabling easy daily inspection around the engine and transmission. The hood opening and closing switch is located inside the AdBlue® tank box on the front left side of the vehicle, allowing the operator to safely operate it from the ground.



### Easy filter replacement

Filters requiring regular maintenance are placed on the left side of the vehicle to improve maintainability. An electric fuel priming pump is equipped as standard.

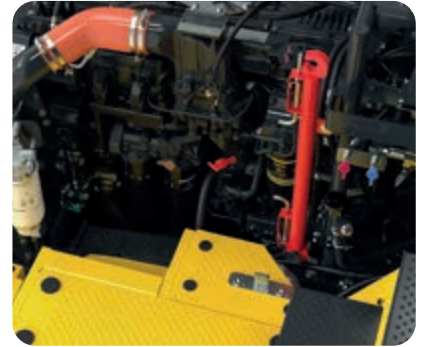

### Easy oil sampling

Oil and coolant sampling ports are provided as standard and are grouped together on the left side of the engine for convenient access.

### Extended service intervals

Further extension of service intervals reduce maintenance interruptions, lower operating costs, and minimise environmental impact.

#### Service intervals:

Engine oil & filters change: 1000 h  
Hydraulic oil filters change: 4000 h  
KDPF cleaning: 8000 h

### Komatsu Care

Komatsu Care is a complimentary customer support program that comes with your new Komatsu machine. Depending on the region, it may include maintenance and/or an additional warranty. Please contact your local distributor for details.

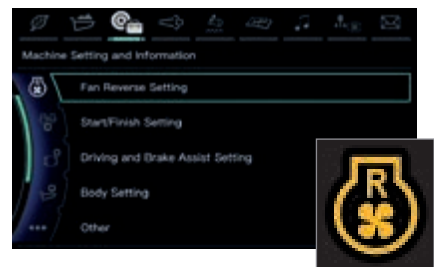

### Reversible fans for easy radiator cleaning

By a touch on the monitor panel, the radiator and aftercooler can be cleaned easily with reversible fans. A clean radiator reduces fuel consumption and increases overall machine performance.

### Maintenance-free batteries

Maintenance-free batteries eliminate routine servicing, saving time. Battery condition is easily confirmed by checking an indicator.



The AdBlue® tank is positioned on the front left side of the vehicle, providing convenient ground-level access for refilling



The tool box has been placed on the front left side of the vehicle



### Maintenance safety features are standard

For safer maintenance, the battery disconnect switch cuts electrical power and the optional starter disconnect switch prevents accidental engine start. Both switches can be operated from ground level without the need for tools.

### Battery jumpstart (option)

A jump-start connector allows the engine to be started from an external battery if the onboard battery is discharged (DC 24 V input).

### Power cab tilt

A power cab tilt system is fitted as standard for easy service access.

### Delayed engine shutdown

When the engine or after-treatment systems are hot, the engine stays running after the start switch is turned off to allow proper cooling. Once temperatures drop to safe levels, the engine shuts down automatically and the main power is switched off.

### Auto power off

The auto power off function prevents battery drain by automatically shutting down the system. If the engine is stationary and there is no monitor operation for a set period, the main power supply switches off automatically.

### Brake inspection guidance



Follow indicated procedures on the monitoring

system to carry out brake capability inspection for each brake. The results will confirm whether the system is operating normally or if its capability has decreased.



### Air cleaner with pre-cleaner

A pre-cleaner is fitted as standard, extending air filter element life by up to 1.7 times compared with the previous model. A built-in handle on the air cleaner element also makes cleaning and replacement quicker and easier.

### Improved windscreen wiper

When switched off, the wipers automatically return to a raised rest position, keeping the blades away from the glass to prevent dust and snow build-up.

### Easier rear window access

A one-touch, tool-free cab guard design provides easy access to the rear window, making cleaning and wiper blade replacement quicker and more convenient.



# Specifications

## Engine

Model	Komatsu DBA127
Type	Common rail direct injection, water-cooled, emissionised, two-stage turbo system, fixed-displacement turbocharger, after-cooled diesel
Engine power	
at rated engine speed	1700 rpm
ISO 14396	386 kW / 518 HP
ISO 9249 (net engine power)	385 kW / 516 HP
Max. torque	2803 N·m / 286 kgf·m
Number of cylinders	6
Bore × stroke	130 × 160 mm
Displacement	12.74 l
Fan drive type	Hydraulic, electric
Governor	All-speed, electronic
Lubrication system	
Method	Gear pump, force-lubrication
Filter	Full-flow type
Air cleaner	Double element type with monitor panel dust indicator and auto dust evacuator
Fuel	Diesel fuel, conforming to EN590 Class 2/ Grade D. Paraffinic fuel capability (HVO, GTL, BTL), conforming to EN 15940:2016

## Transmission

Torque converter	3-elements, 1-stage, 2-phase
Transmission	Full-automatic, planetary type
Speed range	9 speeds forward and 2 reverse
Lock-up clutch	Wet, multi-disc clutch
Shift control	Electronic shift control with automatic clutch modulation in all gears
Maximum travel speed	53.5 km/h
Inter-axle differential lock type	Wet-type multi-disc

## Steering system

Type	Articulated type, fully hydraulic power steering with two double-acting cylinders
Secondary steering	Automatically actuated, electrically powered (meets ISO 5010 and SAE J1511)
Min. turning radius, wall to wall	8.95 m
Articulation angle	45° each direction

## Hydraulic system

Hoist cylinder	Twin, telescopic type
Relief pressure	28.4 MPa (290 kgf/cm <sup>2</sup> )
Hoist time	12 s

## Suspension

Front	Hydro-pneumatic suspension
Rear	Combined hydro-pneumatic and rubber suspension system

## Axles

Drive system	Six wheel drive
Traction control type	KTCS
Cross-axle differential lock type	Wet-type multi-disc
Differential	Spiral bevel gear
Final drive	Planetary gear
Ratios	
Differential	3.063
Planetary	6.000

## Brakes

Brakes meet ISO 3450 standard.	
Service brakes	Full-hydraulic control, oil-cooled multiple-disc type on front and centre axles
Parking brake	Spring applied, caliper disc type
Retarder	Front and centre axle brakes act as retarder
Secondary brake	Manual pedal operation; when hydraulic pressure drops below the specified level, parking brake is automatically actuated

## Tyres

Standard tyres	29.5 R25
----------------	----------

## Cab

Complies with ISO 3471 ROPS (Roll-Over Protective Structure) and ISO 3449 Level II FOPS (Falling Object Protection Structure) standards

## Main frame

Type	Articulated type, box-sectioned construction on front and rear connected by strong torque tubes
------	---

## Weight

Empty weight	32900 kg
Nominal payload	42.0 metric tons
Gross vehicle weight	74900 kg
Weight distribution	
Empty	
Front axle	59.2%
Centre axle	21.7%
Rear axle	19.1%
Loaded	
Front axle	30.4%
Centre axle	36.0%
Rear axle	33.6%

## Body

Capacity	
Struck	18.9 m <sup>3</sup>
Heaped (2:1, SAE)	25.7 m <sup>3</sup>
Body (liner) material	450 HB-class wear-resistant steel
Body (liner) thickness	
Bottom	14 mm
Front	7 mm
Sides	11 mm
Target area	5767 × 3194 mm

## Service refill capacities

Fuel tank	473.0 l
AdBlue® tank	84.4 l
Engine oil	49.0 l
Torque converter, transmission and retarder cooling	89.4 l
Differentials (total)	116.2 l
Final drives (total)	35.8 l
Hydraulic system	138.8 l
Suspension (total)	21.4 l
Cooling system	88.0 l

## Environment

Engine emissions	Fully complies with EU Stage V exhaust emission regulations
Noise level, LpA operator ear	72 dB(A) (ISO 6396 dynamic test)
Vibration levels (EN 12096:1997)	
Hand/arm	≤ 2.5 m/s <sup>2</sup> (uncertainty K = 0.90 m/s <sup>2</sup> )
Body	≤ 0.5 m/s <sup>2</sup> (uncertainty K = 0.31 m/s <sup>2</sup> )
Contains fluorinated greenhouse gas HFC-134a (GWP 1430). Quantity of gas 1.2 kg; CO <sub>2</sub> equivalent 1.72 t	

# Dimensions and performance figures

Unit : mm

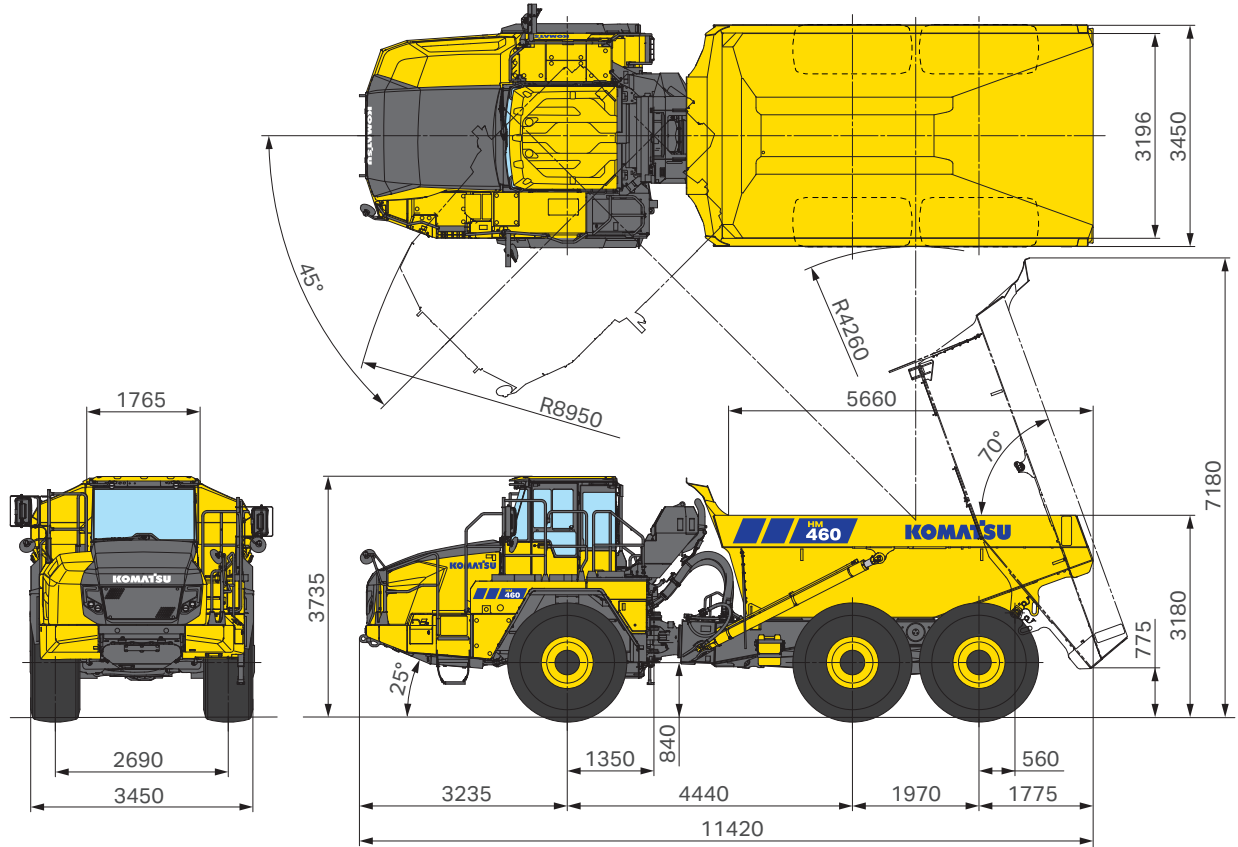

## Travel performance (P-mode)

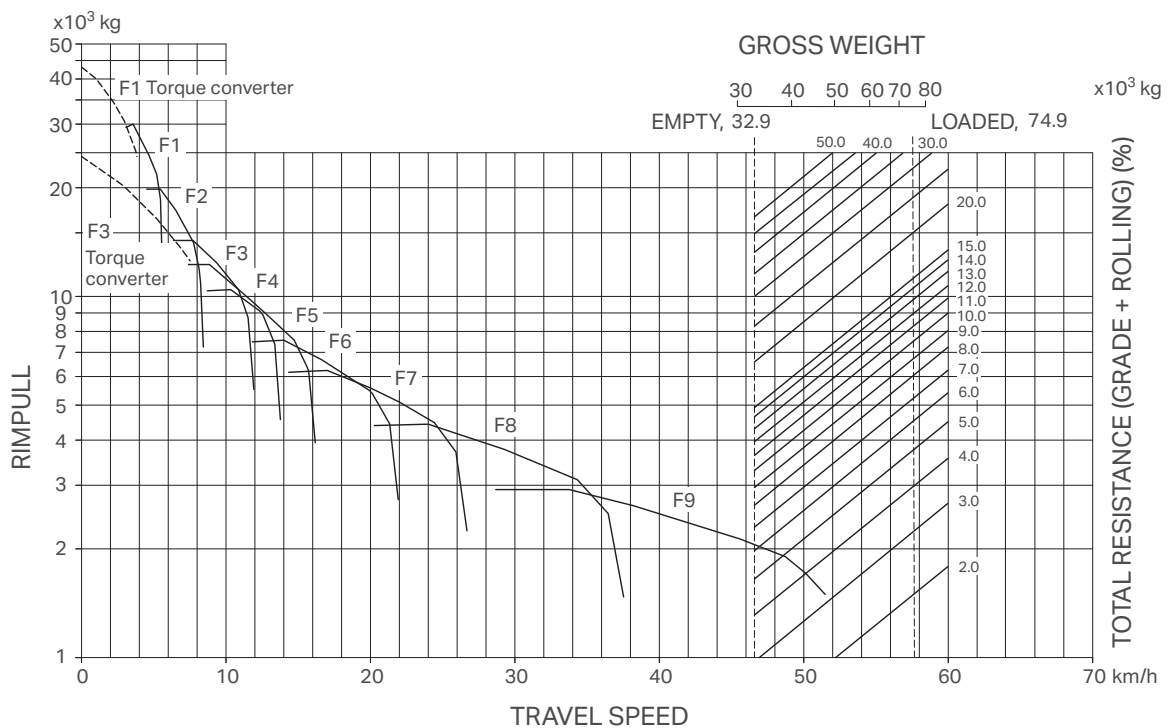

## Retarding guidelines



Gear speed	Continuous downhill gradient [%]	600 m downhill gradient [%]	Speed [km/h]
F1	24 ~ 38	26 ~ 40	6
F2	17 ~ 25	19 ~ 27	9
F3	15 ~ 17	16 ~ 19	10
F4	13 ~ 15	14 ~ 17	12
F5	9 ~ 13	11 ~ 15	16
F6	8 ~ 10	10 ~ 12	23
F7	6 ~ 8	7 ~ 10	27
F8	4 ~ 6	5 ~ 8	39
F9	0 ~ 4	0 ~ 6	56

\* Max. loaded machine: 74900 kg, Tyre size: 29.5 R25

\* Actual grade, not including rolling resistance.

\* Depending on the road resistance, the change in weight or ambient temperature because of the load, the speed limit is changed.

## Body selection

The HM460-6 has multiple body types to choose from, with optional equipment tailored to the user's load conditions available for each body. A no-heating model is also available for all body types.

### Standard body

Suitable for a wide range of uses. Wear-resistant steel plates are installed at key parts of the body to ensure durability.

### Standard body + tailgate

A body with a tailgate installed on the standard body. An option to prevent cargo spillage from the rear of the body.



Bottom plate	t14 / 450 HB-class wear-resistant steel	—
Front plate	t7 / 450 HB-class wear-resistant steel	—
Side plate	t11 / 450 HB-class wear-resistant steel	—
Protector	t7 / 450 HB-class wear-resistant steel	—
Body capacity	25.7 m <sup>3</sup>	26.8 m <sup>3</sup>





# Standard and optional equipment

## Engine

Komatsu DBA127 turbocharged common rail direct injection diesel engine	●
EU Stage V compliant	●
Selectable operating modes: Power mode, Economy mode	●
Air cleaner with pre-cleaner	●
Alternator 24 V / 140 A	●
Starter motor 11.0 kW	●
Batteries 2 × 12 V / 136 Ah	●
Bio diesel fuel, B20	●
Komatsu Diesel Particulate Filter (KDPF)	●
Selective catalytic reduction system (SCR)	●

## Body

Body (25.7 m <sup>3</sup> , 42 t payload)	●
Safety pin	●
Tie-down points	●
Body exhaust heating kit	●
Body tail gate	○
Exhaust heating deletion kit	○

## Guards and covers

Engine small unit guard	●
Engine underguard	●
Exhaust muffler thermal guard	●
Fire prevention covers	●
Mud guards	●
Propeller shaft guards	●
Transmission underguard	●
Lockable fuel cap and covers	○

## Tyres

Tyres 29.5 R25	●
Tyres 875/65 R29	○

## Cab

Tightly sealed ROPS/FOPS cab with viscous mount system, tinted windows, front sun visor, front window wiper with washer and intermittent feature, rear wiper with washer	●
Operator seat, reclining, air suspension type with retractable 3-point seat belt	●
Trainer seat with 2-point retractable seat belt	●
Retractable steering column	●
8-inch machine monitor	●
10-inch rear-view monitor (touchscreen)	●
Keyless start with operator identification system	●
Remote key fob	●
Remote door opener (switch)	●
2 × 12 V power supply socket and USB port power charging	●
3 position hoist control system	●
Air conditioner	●
AM/FM/DAB+/Bluetooth® radio with integrated handsfree microphone	●
Cup holder and magazine rack	●
Large hot and cool box	●
Luggage space and storage tray	●
Smartphone tray	●
Rear cab guard	●
Sun visor, side and rear	●
Operator seat, reclining, air suspension type with 4-point retractable seat belt (2-inch width)	○

## Hydraulic system

Auto Retard Speed Control (ARSC)	●
Adjustable auto idle shutdown	●
Automatic start shift selection	●
Brake inspection guidance	●
Cruise control	●
Dump angle limitation	●
Full automatic F9-R2 transmission with lock-up clutch	●
Hill start assist	●
Hydro pneumatic suspensions (front and rear)	●
KTCS and cross-axle differential lock system	●
Payload meter (PLM)	●
Semi-auto dumping	●
Skip shift function	●
Waiting brake	●

### Safety equipment

Back-up alarm	●
Battery disconnect switch	●
Coolant temperature alarm and light	●
Anti-slip plates	●
Emergency engine stop switch, ground level	●
Secondary engine shutdown switch	●
Fully hydraulic controlled wet multi-disc brakes and retarder system	●
Handrails	●
Electric horn	●
Neutral coast inhibitor	●
Parking brake	●
Protective grille for rear window	●
Rear-view mirrors with heater	●
Rear-view camera system	●
Rollover prevention system	●
Secondary brake	●
Secondary steering	●
Steering joint locking assembly	●
Step (right side) and ladder (left side)	●
Tie-down points	●
Lower side-view mirrors	●
Overload prevention with alarm and speed limit	●
Seat belt reminder with green beacon	●
Speed limiter	●

### LED lighting system

Rear working lights, L.H. and R.H. side	●
Back-up light	●
Clearance lamps	●
Dump lights	●
Fog lights	●
Front working lights	●
Headlights, high beam and low beam	●
Stop / tail lights	●
Turn signal lights with hazard function, front and rear	●
Yellow beacon ready	●

### Service and maintenance

Komtrax Plus – Komatsu wireless monitoring system	●
Komatsu Care program (regional differences apply)	●
PM service connections	●
Electric circuit breakers, 24 V	●
Lightweight wheel chocks	●
Electric priming fuel pump	●
Hydraulically driven fan & electric fan	●
KOWA ports	●
Electrically tiltable cab	●
Electrically tiltable engine hood	●
Tool box and special tool kit	●

### Other equipment

Auto power off	●
Brake cooling oil capture tank	●
Delayed engine shutdown	●
Eco-gauge and Eco-guidance	●
Machine inclination monitoring	●

Further equipment on request

- standard equipment
- optional equipment

---

Your Komatsu partner:

**KOMATSU**

[komatsu.eu](https://www.komatsu.eu)

